



Main features

- Linearity error <math><0,02\%FSO</math>
- Voltage or current output
- Low thermal drift <math><0,01\%FSO/^{\circ}C</math>
- Compact size

The CIR voltage or current amplifiers have been designed to enable the user to adapt non-amplified strain gauge transducers (load cells, pressure transducers) to acquisition systems, PLC, instrumentation with high level inputs. The availability of the output in voltage or current enables the signal to be carried over long distances or used in intelligent automation systems.

TECHNICAL DATA

Model	Voltage B/C/M/N	Current E	meas. unit
Linearity error (FSO)	<math><0.02</math>	<math><0.02</math>	%
Primary sensor resistance ($\pm 10\%$)	350 or 700	350 or 700	Ω
Primary sensor sensitivity	2 or 3	2 or 3	mV/V
Output load resistance	> 10	see diag.	K Ω
Supply voltage	15...30	12...30	Vdc
Current drain with sensor connected	< 33	≤ 20	mA
Supply voltage to transducer	10	0,9	Vdc
Output signal at zero	B/C = 0,1Vdc M/N = 0Vdc	E = 4mA	
Zero signal accuracy (FSO)	<math>< \pm 0,1</math>	<math>< \pm 0,1</math>	%
Zero adjustment (FSO)	> ± 10	> ± 10	%
Full scale output	B = 5,1Vdc C = 10,1Vdc M = 5Vdc N = 10Vdc	E = 20mA	
F.S. output accuracy	<math>< \pm 0,1</math>	<math>< \pm 0,1</math>	%
Span adjustment	> ± 10	> ± 10	%
Inverse polarity protection	YES	YES	
Accidental shortcircuit protection	YES	YES	
Response time (10...90%FSO)	≈ 6	≈ 6	ms
Output noise (RMS10...400Hz)	-60	-60	db
Temp. range: (%FSO)	Compensated Working Storage	0...70 -10...+80 -50...+100	$^{\circ}C$ $^{\circ}C$ $^{\circ}C$
Typical thermal drift of zero (%FSO/ $^{\circ}C$)		$\pm 0,01$	
Typical thermal drift of span (%FSO/ $^{\circ}C$)		$\pm 0,01$	
Length of output cable		1	mt
Case material	Stainless steel / Anodized alum.		
Grade of protection	IP65	IP65	EN 60529
The electrical characteristics are those measured with Vsupply = 24VRL = 1M Ω (Voltage) RL = 500 Ω (Current) Amb.temp = 25 $^{\circ}C$			

MECHANICAL DIMENSIONS

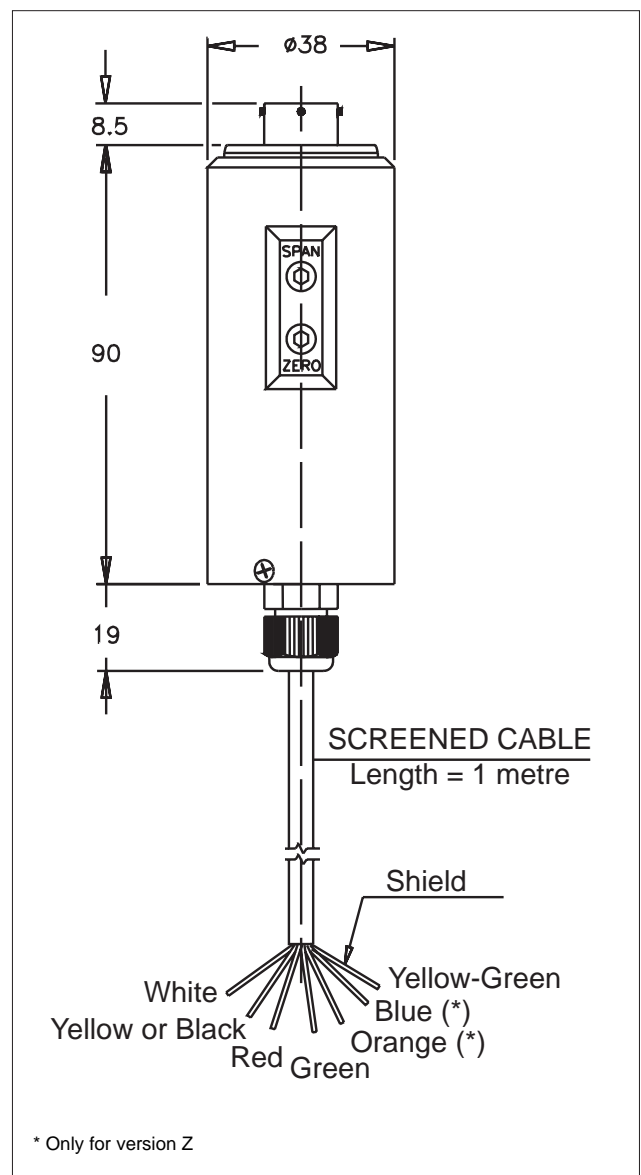

ELECTRICAL CONNECTIONS

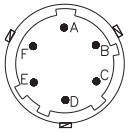

VPT02A 10-6PT2 CONNECTOR

FEMALE CONNECT. PINS CON300	COLOR CODE OUTPUT CABLE
A	Red
B	Yellow / Black
C	White
D	Green
E	Blue
F	Orange

Connector and colour code of cable with prewired female connector.

The amplifiers are fitted with the VPT07RA10-6PT2 male connector. The function of the individual pins varies according to the type of output, as seen in the drawing for models B,C,E,M,N.

ELECTRICAL CONNECTIONS

Mod. B/C/M/N

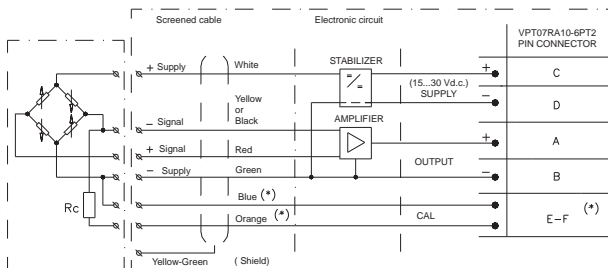

Mod. E

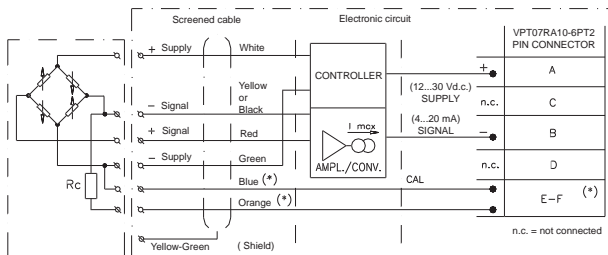

* Only in the version Z (maximum length of the calibration signal wires: 2 metres) the cable screen should be connected to the $_V$ supply of the transducer.

OPTIONAL ACCESSORIES

Connectors

Female cable connector
Protection degree IP66

CON300

Cables and assembled cables

on request

ADJUSTMENT

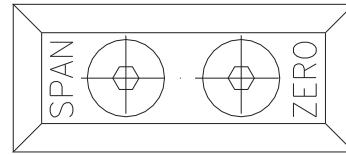

ZERO AND SPAN TRIMMERS

The user can adjust the amplifier zero and gain using two potentiometers (ZERO and SPAN respectively) which are easily accessible from the outside by removing two screws present on the case.

LOAD DIAGRAM

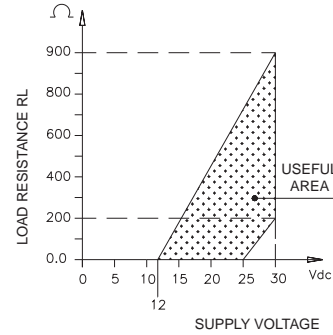

In the diagram shown here, the optimal ratio between the load and the transducer supply is shown for a 4...20mA output.

For a correct use, choose a combination of supply voltage and load resistance that falls within the shaded area.

ORDER CODE

CIR

OUTPUT SIGNAL	
0,1...5,1Vdc	B
0,1...10,1Vdc	C
4...20mA 2 fili	E
0...5 Vdc	M
0...10Vdc	N

PRIMARY ELEMENT SENSITIVITY	
2 mV/V	2
3 mV/V	3

MEASUREMENT BRIDGE RESISTANCE	
350 Ohm	M
700 Ohm	N

CALIBRATION WIRES	
Not fitted	0
Fitted	Z

GEFRAN spa reserves the right to make any kind of design or functional modification at any moment without prior notice.



GEFRAN spa
via Sebina, 74
25050 PROVAGLIO D'ISEO (BS) - ITALIA
ph. 0309888.1 - fax. 0309839063
Internet: <http://www.gefran.com>



cod. 84747-10/99